

HYDRA-2-M™



GEAR DRIVEN POP-UP SPRINKLER

SPECIFICATIONS:

Casting Range	20 - 29 m
Flow	4,2 - 12,8 m ³ /h
Pressure	4,0 - 7,0 bar
Nozzle size	7,0 - 11,0 mm
Nozzles	with 2 and 3 nozzles
Trajectory	25°
Inlet	1 ½" female

AREAS OF APPLICATION:

Golf greens, golf fairways, sports fields, parks

FEATURES:

- Central water routing for high energy efficiency
- Left (+/-90°) and right (30 to 330°) sector adjustable
- Sector adjustment possible while sprinkler is in operation
- Drive, guide and turning device encapsulated
- Rotation speed is variable (130-280 Sec/360°)
- Rear nozzle 4,2 mm for Apron-Irrigation, throwing distance 10 - 11 m
- Ball bearing sprinkler head
- Top service ability: All parts can be serviced from the top, no digging
- Free flushing technology for ascent and descent phase
- Manual control and pressure regulation from the top, with ON-OFF-AUTO position
- 5 years warranty

NEW:

- Improved sand protection
- Housing cover interlocking with locking screw
- Easier installation and maintenance due to CID (decoder with integrated coil)
- Screen to riser interlocking and secured



PERROT
Regnerbau Calw GmbH

Industriestrasse 19-29
D-75382 Althengstett

Tel. +49(0)7051/162-0
Fax +49(0)7051/162-133

perrot@perrot.de
www.perrot.de/en

AVAILABLE VERSIONS

Sprinkler	Features	Measurements				
		A	B	C	D	E
HYDRA-2-M VAC	Full circle gear driven pop-up sprinkler with 3 nozzles	65 mm	80 mm	350 mm	1½" female	172 mm
HYDRA-2-M WVAC	Part circle gear driven pop-up sprinkler with 3 nozzles	65 mm	80 mm	350 mm	1½" female	172 mm
HYDRA-2-M DVAC	Full circle gear driven pop-up sprinkler with 4 nozzles	65 mm	80 mm	350 mm	1½" female	172 mm
HYDRA-2-M WDVAC	Part circle gear driven pop-up sprinkler with 3 nozzles	65 mm	80 mm	350 mm	1½" female	172 mm
HYDRA-2-M SVAC	Full circle gear driven pop-up sprinkler with 3 nozzles, synthetic lawn lid	65 mm	80 mm	350 mm	1½" female	172 mm
HYDRA-2-M WSVAC	Part circle gear driven pop-up sprinkler with 3 nozzles, synthetic lawn lid	65 mm	80 mm	350 mm	1½" female	172 mm
HYDRA-2-M VCID	Full circle gear driven pop-up sprinkler with 3 nozzles, CID Decoder	65 mm	80 mm	350 mm	1½" female	172 mm
HYDRA-2-M WVCID	Part circle gear driven pop-up sprinkler with 3 nozzles, CID Decoder	65 mm	80 mm	350 mm	1½" female	172 mm
HYDRA-2-M DVCID	Full circle gear driven pop-up sprinkler with 4 nozzles, CID Decoder	65 mm	80 mm	350 mm	1½" female	172 mm
HYDRA-2-M W DVCID	Part circle gear driven pop-up sprinkler with 4 nozzles, CID Decoder	65 mm	80 mm	350 mm	1½" female	172 mm
HYDRA-2-M SVCID	Full circle gear driven pop-up sprinkler with 3 nozzles, synthetic lawn lid, CID Decoder	65 mm	80 mm	350 mm	1½" female	172 mm
HYDRA-2-M W SVCID	Part circle gear driven pop-up sprinkler with 3 nozzles, synthetic lawn lid, CID Decoder	65 mm	80 mm	350 mm	1½" female	172 mm
HYDRA-2-M H	Full circle gear driven pop-up sprinkler with 3 nozzles, stop valve	65 mm	80 mm	350 mm	1½" female	172 mm
HYDRA-2-M WH	Part circle gear driven pop-up sprinkler with 3 nozzles, stop valve	65 mm	80 mm	350 mm	1½" female	172 mm
HYDRA-2-M SH	Full circle gear driven pop-up sprinkler with 3 nozzles, synthetic lawn lid, stop valve	65 mm	80 mm	350 mm	1½" female	172 mm
HYDRA-2-M HTC	Full circle gear driven pop-up sprinkler with 3 nozzles, real lawn lid, stop valve	65 mm	126 mm	427 mm	1½" female	116 mm
HYDRA-2-M WHTC	Part circle gear driven pop-up sprinkler with 3 nozzles, real lawn lid, stop valve	65 mm	126 mm	427 mm	1½" female	116 mm
HYDRA-2-M DHTC	Full circle gear driven pop-up sprinkler with 4 nozzles, real lawn lid, stop valve	65 mm	126 mm	427 mm	1½" female	116 mm

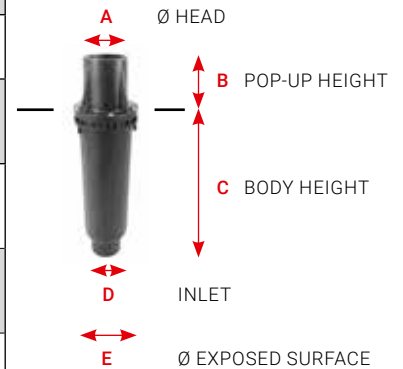
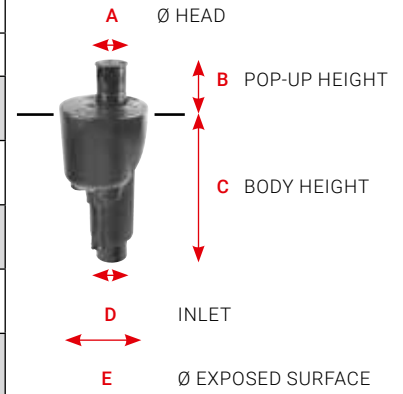

GEAR DRIVEN POP UP-SPRINKLER W. 3 NOZZLES

Operating Pressure	Nozzle 7 mm		Nozzle 8 mm		Nozzle 9 mm		Nozzle 10 mm*		Nozzle 11 mm	
	m³/h	m	m³/h	m	m³/h	m	m³/h	m	m³/h	m
4,0 bar	4,2	20,0	5,4	21,0	6,3	22,0	7,5	23,0	8,6	24,0
5,0 bar	4,8	22,0	6,0	23,0	7,1	24,0	8,4	25,0	9,7	26,0
6,0 bar	5,2	24,0	6,5	25,0	7,8	26,0	9,2	27,0	10,6	28,0
7,0 bar	5,6	25,0	7,0	26,0	8,5	27,0	10,0	28,0	11,4	29,0

* Default Nozzle

GEAR DRIVEN POP UP-SPRINKLER W. 4 NOZZLES

Operating Pressure	Nozzle 7 mm		Nozzle 8 mm		Nozzle 9 mm		Nozzle 10 mm*		Nozzle 11 mm	
	m³/h	m	m³/h	m	m³/h	m	m³/h	m	m³/h	m
5,4	20,0	6,5	21,0	7,4	22,0	8,6	23,0	9,7	24,0	
6,1	22,0	7,3	23,0	8,4	24,0	9,6	25,0	10,9	26,0	
6,7	24,0	7,9	25,0	9,2	26,0	10,6	27,0	11,9	28,0	
7,2	25,0	8,5	26,0	9,9	27,0	11,5	28,0	12,8	29,0	

* Default Nozzle

Casting range valid at minimum adjustable rotation speed, Radius derived from tests under real conditions, with rotating sprinkler installed at ground level (sprinkler model without valve)



PERROT
Regnerbau Calw GmbH

Industriestrasse 19-29
D-75382 Althengstett

Tel. +49(0)7051/162-0
Fax +49(0)7051/162-133

perrot@perrot.de
www.perrot.de/en